

Vakuumpumpen

Instrumente

Bauteile und Ventile

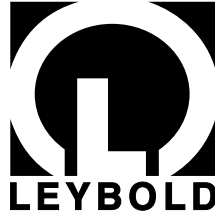

LEYBOLD VAKUUM

ET 01.200/15

TRIVAC

S 1,6 B; D 1,6 B

Drehschieber-Vakuumpumpe

Rotary Vane Vacuum Pump

Pompe rotative à vide
à palettes

Gültig ab Kat.-Nr. / Fabrikations-Nr.

Valid from Cat.-No. / Serial-No.

Valable à partir du No. de Cat. /

No. de Fabrication

102 25 A96 13 00001

102 26 A96 13 00001

102 27 A96 13 00001

112 25 A96 13 00001

112 26 A96 13 00001

112 27 A96 13 00001

112 31 A96 11 00001

Ersatzteilliste

Spare Parts List

Liste des pièces de rechange



Abb./Fig. 1 TRIVAC S/D 1,6 B



Abb./Fig. 2 TRIVAC S/D 1,6 B

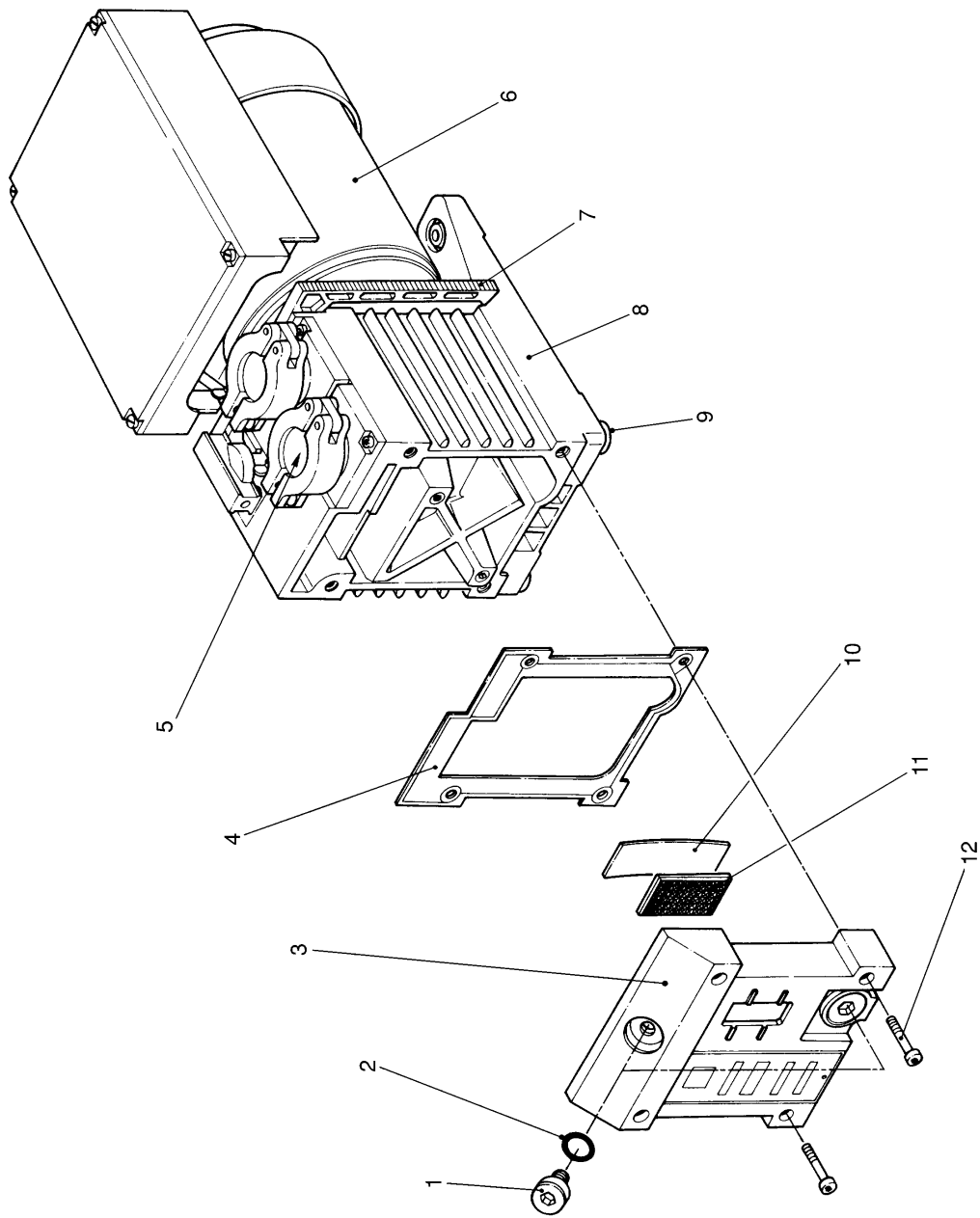

Innenteil D 1,6 B
 Cylinder assembly D 1,6 B
 Corps de pompe D 1,6 B

Innenteil S 1,6 B
 Cylinder assembly S 1,6 B
 Corps de pompe S 1,6 B

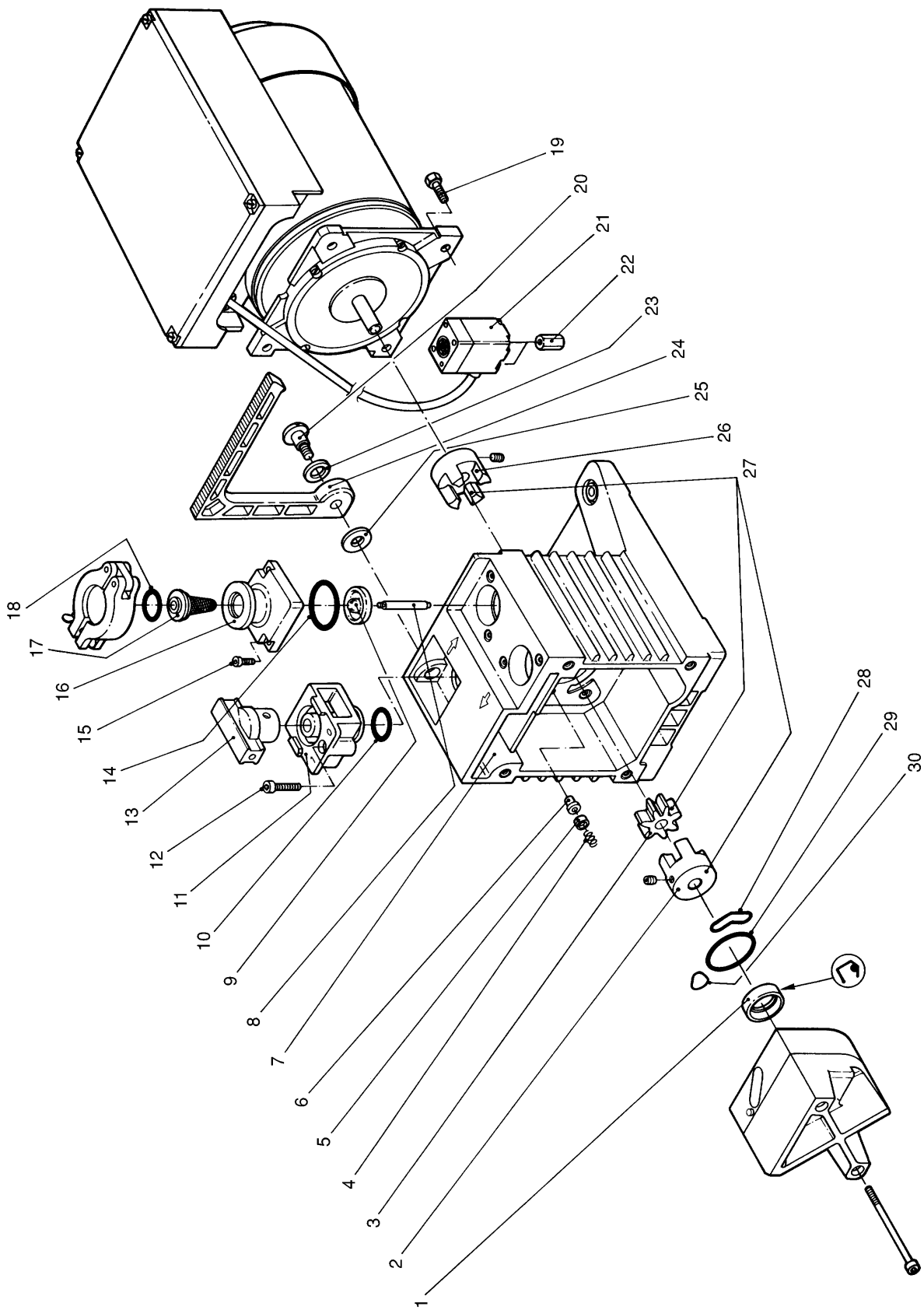
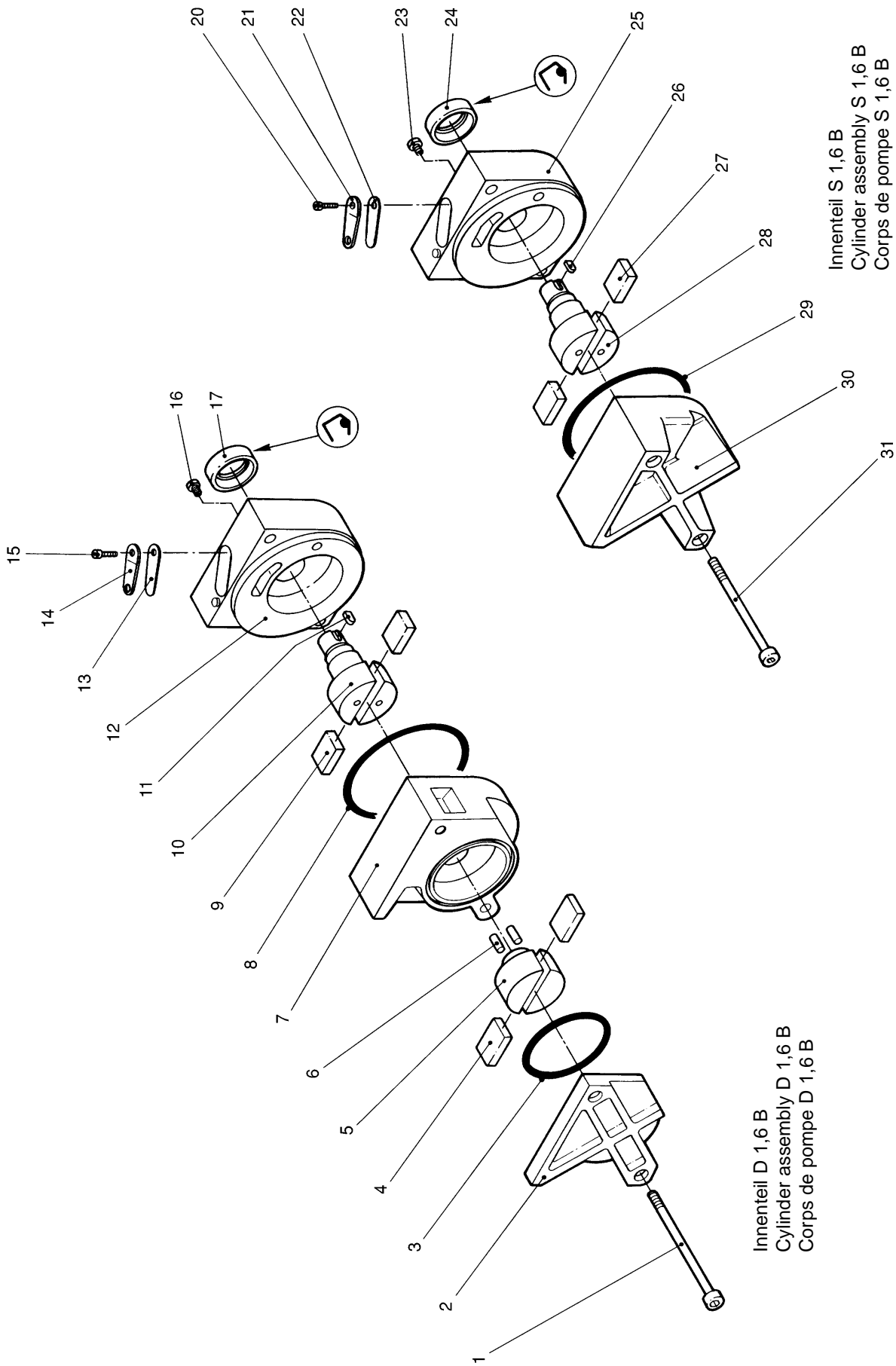
Abb./Fig. 3

LEYBOLD VAKUUM GmbH

Bonner Straße 498 (Bayenthal)
D-50968 Köln
Telefon:(0221) 347-0
Telefax:(0221) 347-1250